

Parameter Value set

2531 GstarCAD MY /KW November 9, 2021 [Workflow](#) 0 640

For mechanical designs, we often need to stretch the keyway to a certain length. Now, let us see how to realize an accurate stretch.

Pick linear parameter in block editor ([BEDIT](#)), click entry frame which is on the right side of " distance type" on the Properties panel, a drop-down menu. will appear

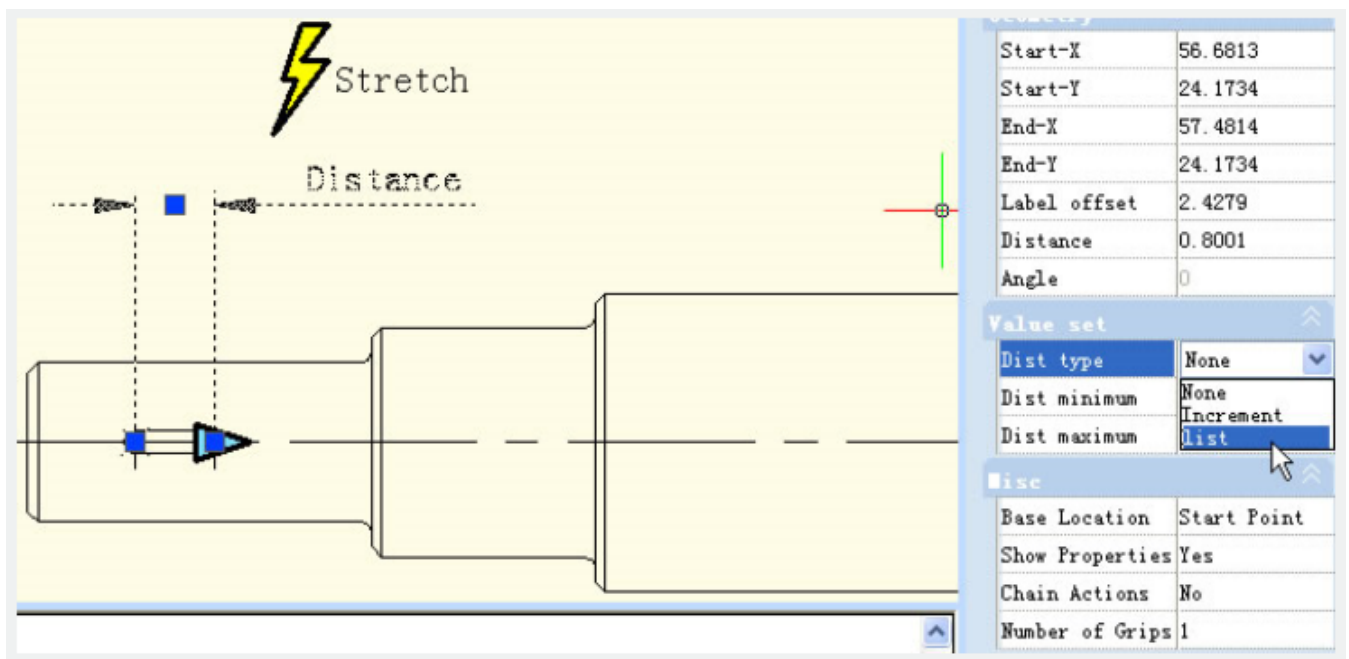

Therein, none is the default option, which means it can stretch optionally. With the other two options, you can define the maximum and minimum number respectively.

"Increment" means stretch increasingly, a Value set appears as shown below after selecting increment.

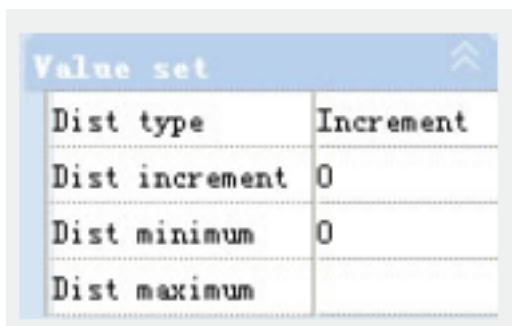

If you choose "list", a Value set appears as shown in below picture, the dynamic block can only be

stretched according to the number in the list.

Value set	
Dist type	list
Dist value list	0.8001

Click the text frame which is on the right side of the "distance value list", one button with ellipsis on it will appear. Click this button, a "Add distance" dialog box will be displayed. Add three numbers "1"."1.5"."2" in the dialogue box, as shown in below picture.

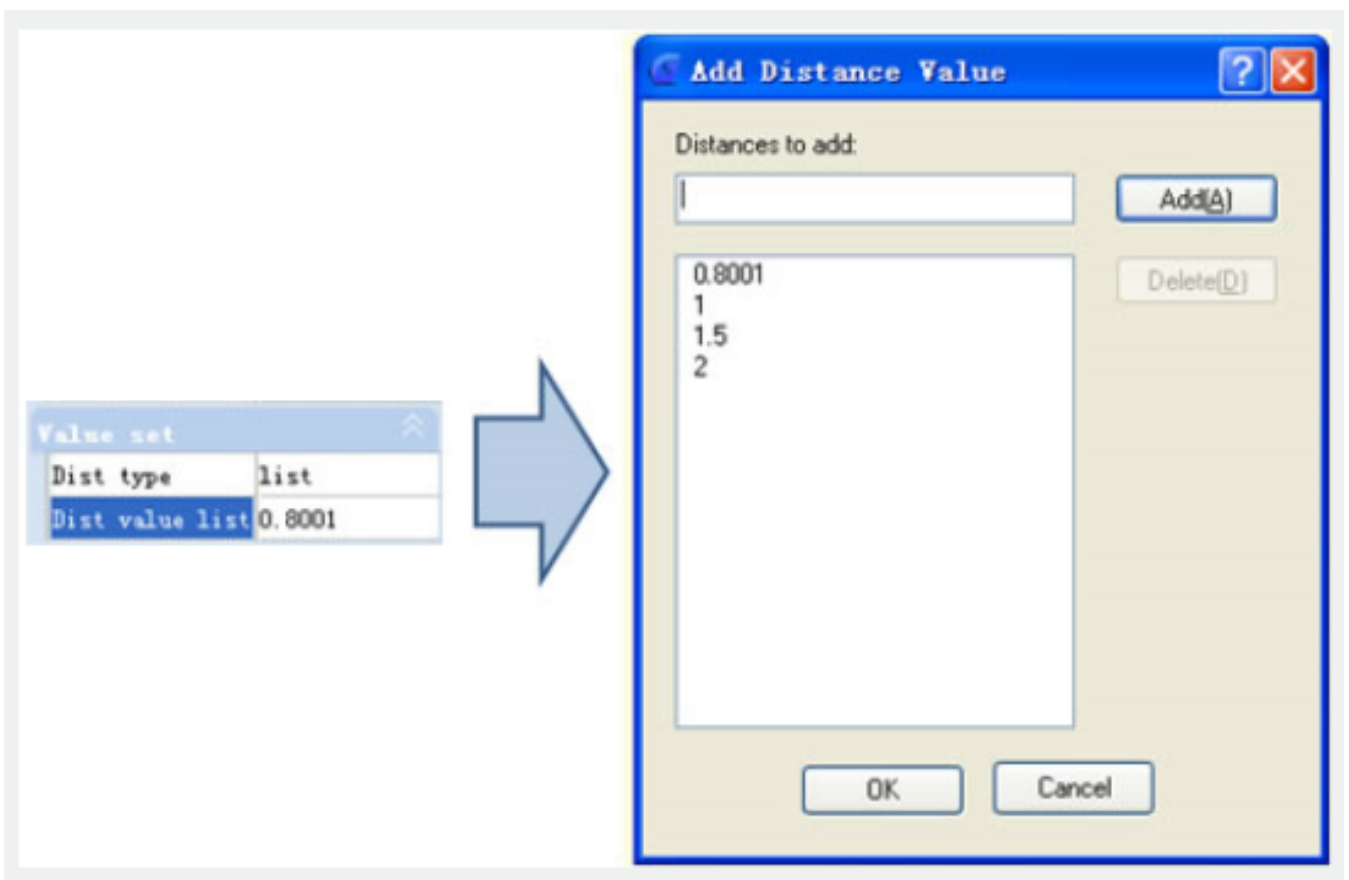

Exit from block editor and stretch the right grip, you will see several gray lines appearing on the right side of the keyway, and the keyway can only be stretched to the gray line position, as shown in below picture. Obviously, by value list, you can define certain numbers of the stretch, to realize an accurate stretch.

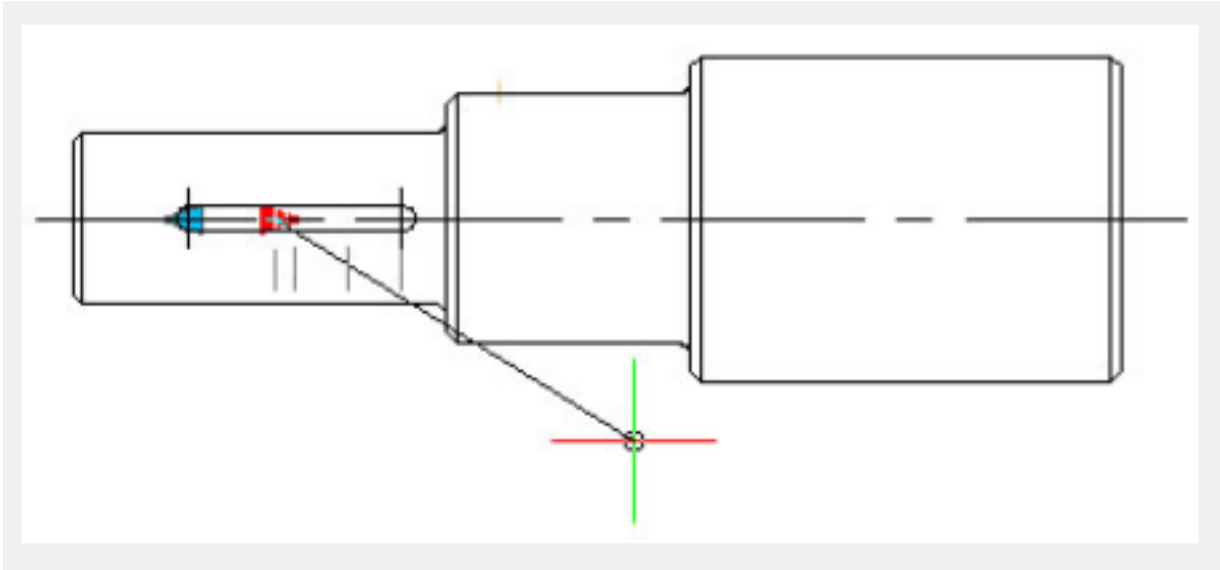

Online URL: <https://www.gstarcad.com.my/knowledge/article/parameter-value-set-2531.html>